

Steel Clamp Half Couplings Adaptors & Bobbins



R & D Marine has developed a comprehensive range of competitively priced Steel Clamp Half Couplings with flange sizes from 4 to 7 1/4 inch diameter.

Steel Clamp Half Couplings can accommodate the variations that occur with normal shaft tolerances, are easy to install and can be adjusted to the required position on the shaft.

R & D Marine have the capacity to machine Split Half Couplings to special sizes not in the literature.

R & D Marine can also offer pilot drilled Solid Half Couplings suitable for parallel and taper boring. Adaptors to fit larger couplings to gearbox flanges and Bobbins to extend the shaft.

Products are available ex-stock and worldwide through our distribution network.

- Clamps to give a better fit than a solid coupling
- Machined from solid steel
- Able to accommodate normal shaft tolerances
- Available in standard sizes (Both Metric and Imperial)
- Easy to install and position
- Wide range of stock
- Competitively priced
- In - House customization
- Special Half Couplings can be supplied in small batches
- Worldwide availability

R & D Marine Steel Split Half Couplings

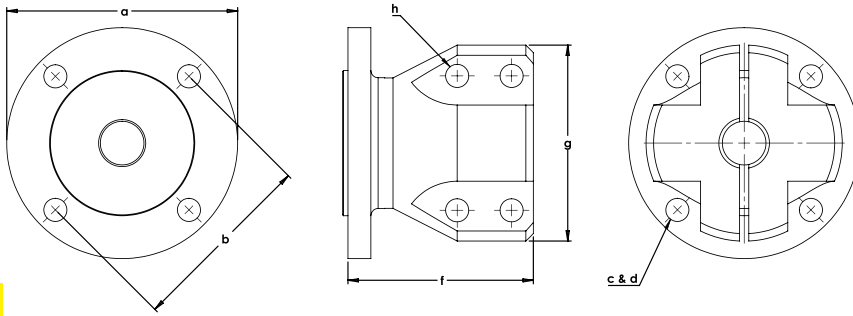

Supplied with Shaft Clamp Bolts and Nuts

Imperial Sizes

Keyways to BS46: Part 1 Square

Metric Sizes

Keyways to BS4235: Part 1 Rectangular

Shaded area designates range of bores covered.

Units of measurement: Black Millimetres Red Inches

Part No	Type of Gearbox	Imperial Bore Diameters (Inch)										Coupling Dimensions								
		-	-	B	D	F	H	J	K	L	M	a	b	c	d	e	f	g	h	
		.750	21mm	1.00	1.250	1.50	1.750	2.00	2.250	2.50	2.750	Flange Diameter	Hole Pitch Circle	No of Holes	Hole Size	Register Diameter M = Male F = Female	Length	Boss Diameter	Clamp Bolt Size	
202-153	4" BW, PRM, Hurth Max Bore 1.500	B		B	B	B						102.0 4.00	82.55 3.25	4	10.0 0.394	63.5 2.50	M	81.0 3.19	85.9 3.38	M10
202-254	4" Yanmar Max Bore 1.500	B		B	B							102.0 4.00	78.00 3.07	4	10.0 0.394	50.0 1.97	M	81.0 3.19	85.9 3.38	M10
202-255	4" Volvo Max Bore 1.500	B										102.0 4.00	80.00 3.15	4	10.0 0.394	60.0 2.36	F	85.8 3.28	85.9 3.38	M10
202-489	4" Bukh Max Bore 1.500	B										90.0 3.54	74.5 2.93	4	8.1 0.32	47.0 1.85	F	85.8 3.28	85.9 3.38	M10
202-168	5" BW, PRM, Hurth, Volvo. Max Bore 2.000		P	B	BK	BK	BK	BK				127.0 5.00	107.95 4.25	4	11.2 0.44	63.5 2.50	M	95.3 3.75	103.2 4.06	7/16
202-316	5" Yanmar Max Bore 2.000		P		BK							119.9 4.72	100.00 3.94	4	10.0 0.394	65.0 2.56	M	95.3 3.75	103.2 4.06	M10
202-176	6" PRM Max Bore 2.500		P		BK	BK	BK	BK	BK	BK		146.0 5.75	120.6 4.75	6	12.7 0.50	76.2 3.00	M	139.7 5.50	136.7 5.38	1/2
202-188	6" Twin Disc Max Bore 2.500		P			BK	BK					146 5.75	120.6 4.75	6	16.0 0.63	76.2 3.00	F	139.7 5.50	136.7 5.38	1/2
202-313	5" IRM 220, MG 502 Lister, Max Bore 2.000		P									127.0 5.00	98.6 3.88	6	12.0 0.47	63.5 2.50	F	143.0 5.63	103.2 4.06	7/16
202-381	7 1/2" PRM 601, 1000 4:1 Max Bore 2.750					P						189.2 7.45	152.4 6.00	6	16.0 0.63	95.25 3.75	M	190.5 7.50	168.4 6.63	5/8
202-468	7 1/2" PRM 1500 Max Bore 2.750					P						189.2 7.45	152.4 6.00	6	16.0 0.63	95.25 3.75	F	190.5 7.50	168.4 6.63	5/8
202-469	7 1/2" Twin Disc Max Bore 2.750					P						189.2 7.45	152.4 6.00	6	19.0 0.75	95.25 3.75	F	190.5 7.50	168.4 6.63	5/8
202-470	7 1/2" ZF 311A Max Bore 2.750					P						189.2 7.45	152.4 6.00	8	16.0 0.63	95.25 3.75	F	190.5 7.50	168.4 6.63	5/8

Part No	Type of Gearbox	Metric Bore Diameters (mm)										Coupling Dimensions								
		B	C	D	F	H	J	K	L	M	N	a	b	c	d	e	f	g	h	
		22	25	30	35	40	45	50	55	60	70	Flange Diameter	Hole Pitch Circle	No of Holes	Hole Size	Register Diameter M = Male F = Female	Length	Boss Diameter	Clamp Bolt Size	
202-165	4" BW, PRM, Hurth Max Bore 40mm		B	B	B							102.0 4.00	82.55 3.25	4	10.0 0.394	63.5 2.50	M	81.0 3.19	85.9 3.38	M10
202-257	4" Yanmar Max Bore 40mm		B	B								102.0 4.00	78.00 3.07	4	10.0 0.394	50.0 1.97	M	81.0 3.19	85.9 3.38	M10
202-258	4" Volvo Max Bore 40mm		B	B								102.0 4.00	80.00 3.15	4	10.0 0.394	60.0 2.36	F	85.8 3.28	85.9 3.38	M10
202-490	4" Bukh Max Bore 40mm											90.0 3.54	74.5 2.93	4	8.1 0.32	47.0 1.85	F	85.8 3.28	85.9 3.38	M10
202-171	5" BW, PRM, Hurth Volvo. Max Bore 50mm			BK	BK	BK	BK	BK				127.0 5.00	107.95 4.25	4	11.2 0.44	63.5 2.50	M	95.3 3.75	103.2 4.06	7/16
202-300	5" Yanmar Max Bore 50mm			BK	BK							119.9 4.72	100.00 3.94	4	10.0 0.394	65.0 2.56	M	95.3 3.75	103.2 4.06	M10
202-178	6" PRM Max Bore 60mm					BK	BK	BK	BK	BK		146.0 5.75	120.6 4.75	6	12.7 0.50	76.2 3.00	M	139.7 5.50	136.7 5.38	1/2
202-314	6" Twin Disc Max Bore 60mm							BK		BK		146 5.75	120.6 4.75	6	16.0 0.63	76.2 3.00	F	139.7 5.50	136.7 5.38	1/2
202-315	5" IRM 220, MG 502 Lister, Max Bore 50mm											127.0 5.00	98.6 3.88	6	12.0 0.47	63.5 2.50	F	143.0 5.63	103.2 4.06	7/16
202-466	7 1/2" PRM 601, 1000 4:1 Max Bore 70mm											189.2 7.45	152.4 6.00	6	16.0 0.63	95.25 3.75	M	190.5 7.50	168.4 6.63	5/8
202-471	7 1/2" PRM 1500 Max Bore 70mm											189.2 7.45	152.4 6.00	6	16.0 0.63	95.25 3.75	F	190.5 7.50	168.4 6.63	5/8
202-472	7 1/2" Twin Disc Max Bore 70mm											189.2 7.45	152.4 6.00	6	19.0 0.75	95.25 3.75	F	190.5 7.50	168.4 6.63	5/8
202-473	7 1/2" ZF 311A Max Bore 70mm											189.2 7.45	152.4 6.00	8	16.0 0.63	95.25 3.75	F	190.5 7.50	168.4 6.63	5/8

P - Pilot Drilled Open Tolerance

B - Bored Only

BK - Bored & Keyed

Recommended tightening torque:

M10 - 61 Nm 45 lbsft

7/16 UNF - 81 Nm 60 lbsft

1/2 UNF - 100 Nm 75 lbsft

5/8 UNF - 210 Nm 155 lbsft

R & D Marine Gearbox Output Flange Adaptors

R & D Marine can provide an adaptor for most gearboxes to allow the fitting of a flexible coupling from their extensive range. If the gearbox fitting you require is not listed please contact R & D Marine.

Flange machined to suit the gearbox output flange.
The register could be male or female
See listing below.

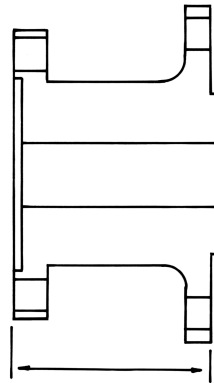

Length to clear oil pump etc

Flange machined to fit the selected R & D Flexible Coupling.
The register could be male or female.

Gearbox	Gearbox Register	Coupling	Maximum HP of Coupling		Effective length of Coupling		R & D Marine Reference	Effective length of Adaptor	
			kW	HP	Mm	Inch		Mm	Inch
B/W, PRM, ZF-Hurth, Twin Disc, Volvo									
4" to 5"	Female	910-029	14.92	20	52.4	2.06	202-351	22.3	0.88
5" to 6"	Female	910-032	27.6	37	55.4	2.18	202-411	74.7	2.94
Twin Disc									
MG 502	Male	910-032	27.6	37	55.4	2.18	202-148	54	2.13
MG 5075A	Male	910-039	41	55	63.3	2.49	EXP 249	69.9	2.75
MG 5090A	Male	910-024	63.1	85	56.7	2.23	EXP 244	193.7	7.63
MG 5111 SC	Male	910-022	44	65	44.5	1.75	EXP 147	17.8	0.70
MG 5111	Male	910-022	44	65	44.5	1.75	EXP 193	115.9	4.56
MG 5114	Male	910-025	20.9	28	49.8	1.96	EXP 184-2	45	1.75
MG 5114A	Male	910-024	63.1	85	56.7	2.23	EXP 205	155.7	6.13
MG 5114A	Male	910-030	89.52	120	58.4	2.30	EXP 238	155.7	6.13
MG 5135A	Male	910.024	67.5	85	56.7	2.23	202-477	62.5	2.5
MGX 5145 SC	Male	910-025	20.9	28	49.8	1.96	EXP 251	45	1.75
MGX 5145 SC	Male	910-030	89.4	120	58.5	2.30	EXP 253	135	5.32
MGX 5145 SC	Male	910-030	89.4	120	58.5	2.30	EXP 260	159	6.25
MG 6449	Male	910-030	89.4	120	58.5	2.30	EXP 208	46	1.81
ZF-Hurth									
BW 61	Male	910-018	29.84	40	60.7	2.39	EXP 221	122.0	4.81
BW 120	Male	910-025	20.9	28	49.8	1.96	EXP 182	76	3.00
BW 195VP, 1950A 2000, 2050, 2050A	Male	910-035	215	160	108.0	4.25	EXP 242	241.3	9.50
BW 250A 255A, 255AP	Male	910-030	89.52	120	58.4	2.30	EXP 239	155.8	6.13
BW 255 VP	Male	910-045	171.4	230	108.0	4.25	EXP 246	181	7.13
HSW 630 A1	Female	910-025	20.9	28	49.8	1.96	EXP 240	75	2.96
ZF 2000	Male	910-030	89.52	120	58.4	2.30	EXP 247	241	9.50
ZF 2500A	Male	910-030	89.52	120	58.4	2.30	202-412	156	6.13
ZF 2500A	Male	910-035	215	160	108.0	4.25	EXP 266	150	4.25
ZF 550A	Male	910-030	89.52	120	58.4	2.30	EXP 245	124	4.88
IRM 220A	Male	910-032	27.6	37	55.4	2.18	202-384	54	2.13
IRM 280A	Male	910-039	41	55	63.5	2.49	202-382	97	3.82
IRM 280A	Male	910-039	41	55	63.5	2.49	EXP 224 R1	25.4	1.00
IRM 280A	Male	910-039	41	55	63.5	2.49	202-387	50.8	2.00
IRM 305A	Male	910-033	27.6	37	55.4	2.18	EXP 234	115	4.53
IRM 311A	Male	910-039	41	55	63.5	2.49	EXP 230	108	4.25
IRM 311A	Male	910-024	63.1	85	56.7	2.23	EXP 259	266.7	10.50
IRM 311A	Male	910-040	41	55	63.5	2.49	EXP 243	117.6	4.65
IRM 305A	Male	910-040	41	55	63.5	2.49	EXP 261	130.0	5.12
IRM 311-PL	Male	910-024	63.1	85	56.7	2.23	EXP 227	135	5.32
IRM 320A	Male	910-018	29.84	40	60.7	2.39	EXP 130	165.1	6.50
IRM 320AL	Male	910-022	44	65	44.5	1.75	EXP 170	106	4.18
IRM 320A-1	Male	910-024	63.1	85	56.7	2.23	EXP 200	106	4.18
IRM 325A ZF 12 Bolt	Male	910-024	63.1	85	56.7	2.23	202-392	178	7.00
IRM 325 IV	Male	910-039	41	55	63.5	2.49	202-467	111	4.38
IRM 325 IV	Male	910-040	41	55	63.5	2.49	202-474	50.8	2.00
IRM 325A Volvo 10 Bolt	Male	910-024	63.1	85	56.7	2.23	EXP 232	178	7.00
IRM 350A	Male	910-024	63.1	85	56.7	2.23	EXP 177	152.4	6.00
IRM 350A	Male	910-018	63.1	40	60.7	2.39	EXP 207	125	4.92
W350A	Male	910-024	63.1	85	56.7	2.23	202-443	130	5.13

R & D Marine Steel Half Couplings

Pilot drilled only for finish parallel or taper boring by customer

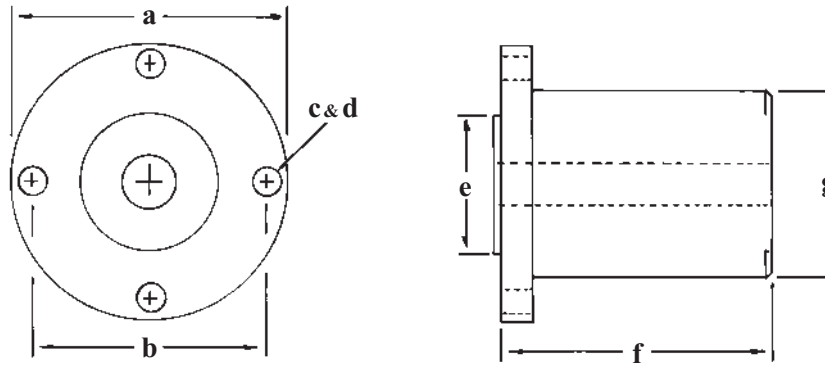

Part No	Type of Gearbox	Pilot drilled only Customer to finish bore	a	b	c	d	e		f	g
			Flange Diameter	Hole Pitch Circle	No of Holes	Hole Size	Register Diameter		Length	Boss Diameter
202-026	4" BW, PRM Hurth	Pilot drilled to 16.5mm diameter	102.0 4.00	82.55 3.25	4	10.0 0.394	63.5 2.50	M	54.9 2.16	57.2 2.25
202-027	5" B/W, PRM Hurth, Volvo	Pilot drilled to 19.0mm diameter	127.0 5.00	107.95 4.25	4	11.2 0.44	63.5 2.50	M	54.9 2.16	85.9 3.38
202-006	5" B/W, PRM Hurth, Volvo	Pilot drilled to 19.0mm diameter	127.0 5.00	107.95 4.25	4	11.2 0.44	63.5 2.50	M	124.5 4.90	85.9 3.38
202-037	6" PRM	Pilot drilled to 21.0mm diameter	146.0 5.75	120.6 4.75	6	12.7 0.50	76.2 3.00	M	89.4 3.52	92.7 3.65
202-054	6" PRM	Pilot drilled to 21.0mm diameter	146.0 5.75	120.6 4.75	6	12.7 0.50	76.2 3.00	M	149.0 5.87	92.7 3.65
202-120	6" Twin Disc	Pilot drilled to 21.0mm diameter	146.0 5.75	120.6 4.75	6	16.0 0.63	76.2 3.00	F	152.4 6.00	92.7 3.65

R & D Marine Bobbins

R & D Marine can provide a Bobbin to extend the shaft. If the gearbox fitting you require is not listed, please contact R & D Marine

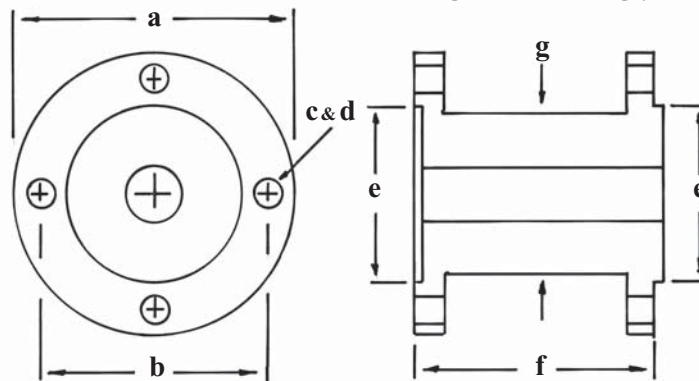

Part No	Type of Gearbox	Bobbin Dimensions							
		a Flange Diameter	b Hole Pitch Circle	c No of Holes	d Hole Size	e Register Diameter	f Length	g Neck Diameter	
202-169	4" BW, PRM Hurth	102.0 4.00	82.55 3.25	4	10.0 0.394	63.5 2.50	M/F	87.4 3.44	57.2 2.25
202-251	5" BW, PRM Hurth, Volvo	127.0 5.00	107.95 4.25	4	11.2 0.44	63.5 2.50	M/F	124.5 4.90	85.9 3.38
202-250	6" PRM	146.0 5.75	120.6 4.75	6	12.7 0.50	76.2 3.00	M/F	148.9 5.86	92.7 3.65
Exp 225	7 1/4" Twin Disc	184.2 7.25	152.4 6.00	6	19.0 0.75	95.25 3.75	M/F	152.4 6.00	108.0 4.25

Units of measurement: Black Millimetres Red Inches

R & D
MARINE LTD.

Meadow Works
Clothall Road, Baldock
Hertfordshire
England
SG7 6PD

Contact Us By:
Tel: +44 (0)1462 892391
Fax: +44 (0)1462 896448
Web Site: www.randdmarine.com
E mail: info@randdmarine.com

Designs are subject to constant review and improvement therefore we reserve the right to amend any dimension or detail specified or illustrated in this publication without notice and without incurring any obligation to provide such modification to products previously delivered.